

Line-No.	Date	27.02.2012	Order-No.		Amount		Supplier Laserpack Fryazino
	Path	aserpack/filesW	Author	Yashin A	Height		
	File	f> ECMA_F01...dds	Customer		Manufacturer		
	10/15/18		Line type		Material		
	Sonstiges		Pointage		Mat. Table		

Rule Processing System ACS 100 for ISO 9000

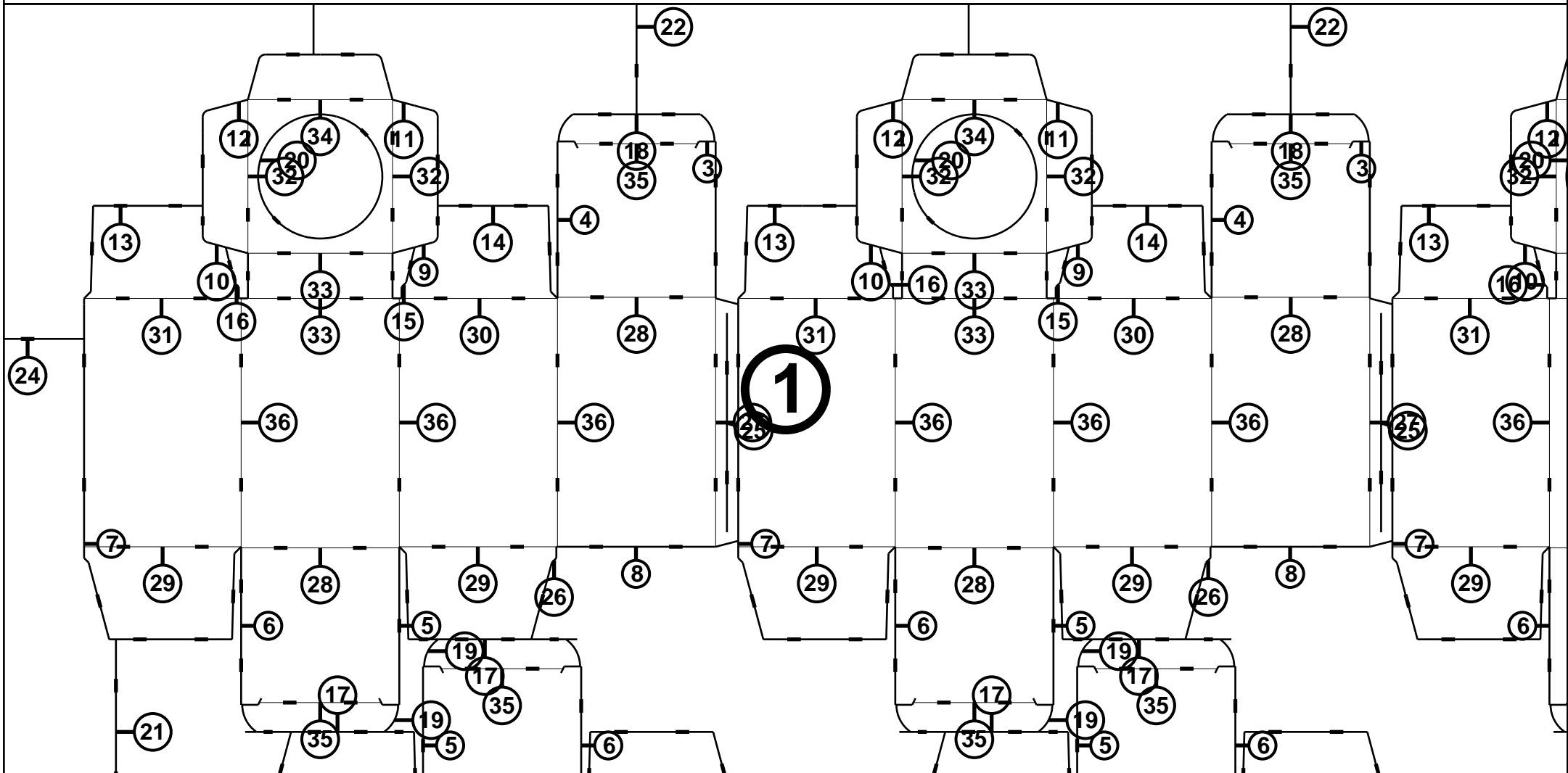

Line-No.	Date	27.02.2012	Order-No.		Amount		Supplier Laserpack Fryazino
	Path	aserpack/filesW	Author	Yashin A	Height		
	File	f> ECMA_F01...dds	Customer		Manufacturer		
	10/15/18		Line type		Material		
	Sonstiges		Pointage		Mat. Table		
							Die-Side

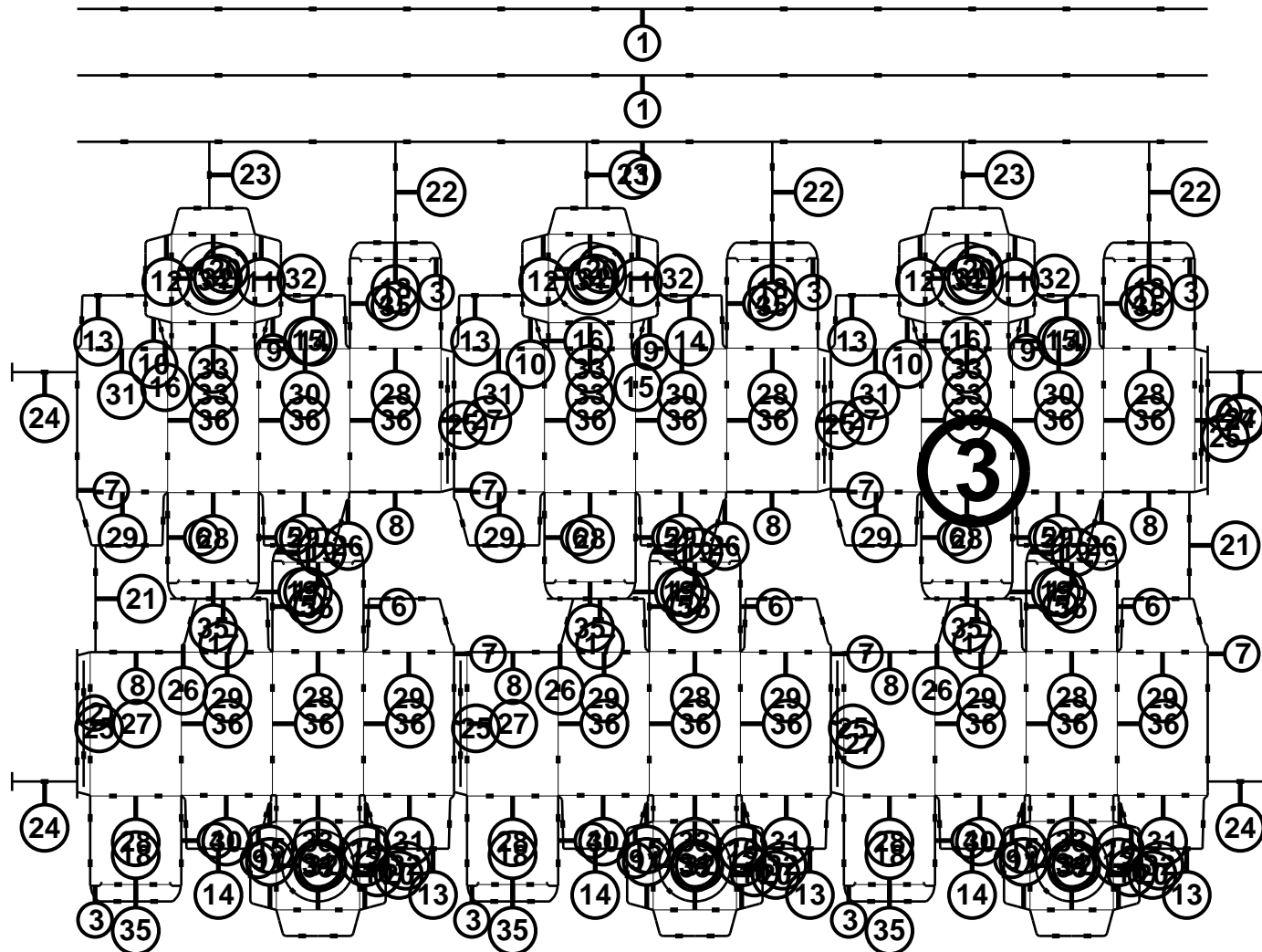

Line-No.	Date	27.02.2012	Order-No.		Amount		Supplier Laserpack Fryazino
	Path	aserpack/filesW	Author	Yashin A	Height		
	File	f> ECMA_F01...dds	Customer		Manufacturer		
	10/15/18		Line type		Material		
	Sonstiges		Pointage		Mat. Table		

Rule Processing System ACS 100 for ISO 9000

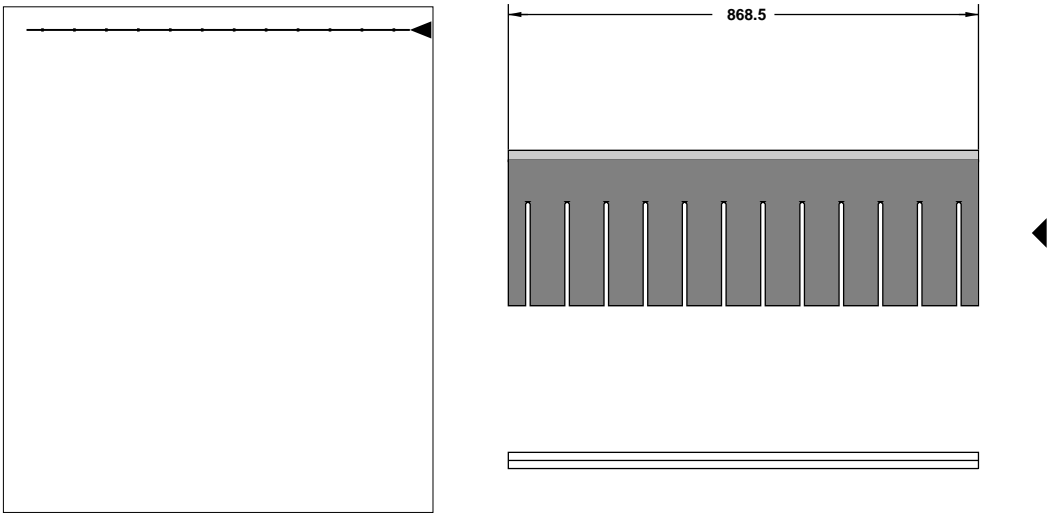

1	Line-No.	Date	27.02.2012	Order-No.		Amount	3	Supplier	
	Path	asercpack/filesW	Author	Yashin A	Height	23.80		Laserpack Fryazino	
	File	f> ECMA_F01...dds	Customer		Manufacturer	Boehler			
	10/15/18		Line type	Cut	Material	UNIVERSAL-T30			
	Sonstiges		Pointage	2.00	Mat. Table	04	Die-Side		

Rule Processing System ACS 100 for ISO 9000

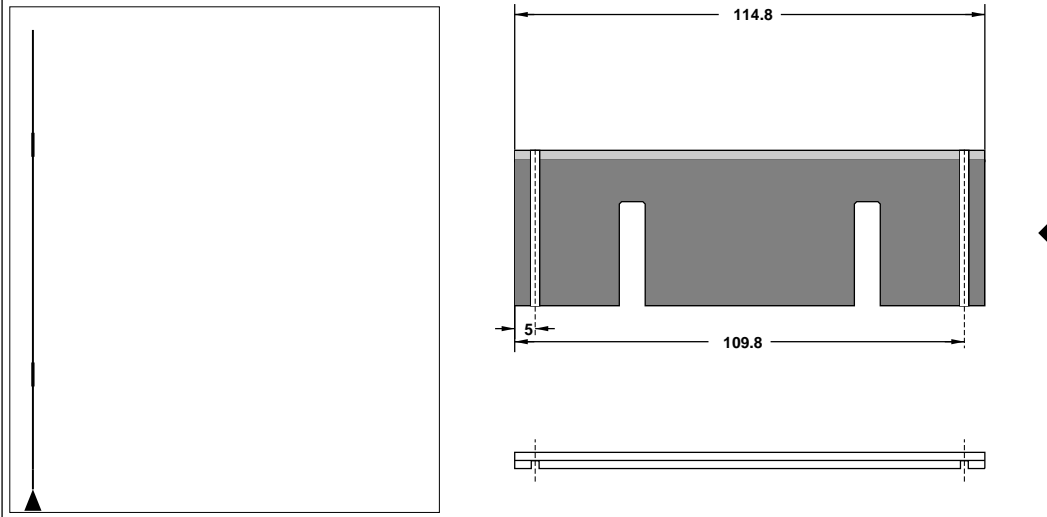

2	Line-No.	Date	27.02.2012	Order-No.		Amount	2	Supplier	
	Path	asercpack/filesW	Author	Yashin A	Height	23.80		Laserpack Fryazino	
	File	f> ECMA_F01...dds	Customer		Manufacturer	Boehler			
	10/15/18		Line type	Cut	Material	UNIVERSAL-T30			
	Sonstiges		Pointage	2.00	Mat. Table	04	Die-Side		

Rule Processing System ACS 100 for ISO 9000

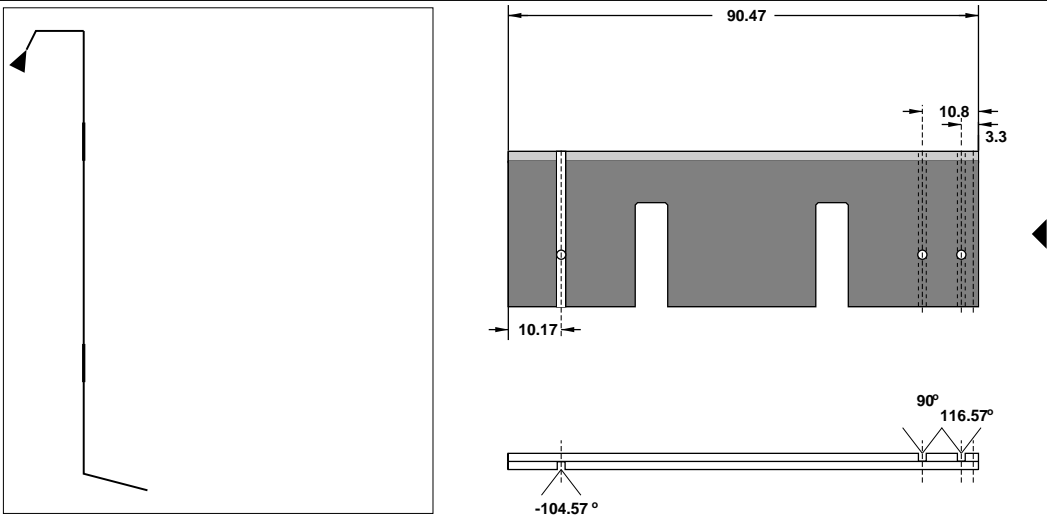

3	Line-No.	Date	27.02.2012	Order-No.		Amount	6	Supplier	
	Path	asercpack/filesW	Author	Yashin A	Height	23.80		Laserpack Fryazino	
	File	f> ECMA_F01...dds	Customer		Manufacturer	Boehler			
	10/15/18		Line type	PERFO	Material	UNIVERSAL-T30			
	Sonstiges		Pointage	2.00	Mat. Table	04	Die-Side		

Rule Processing System ACS 100 for ISO 9000

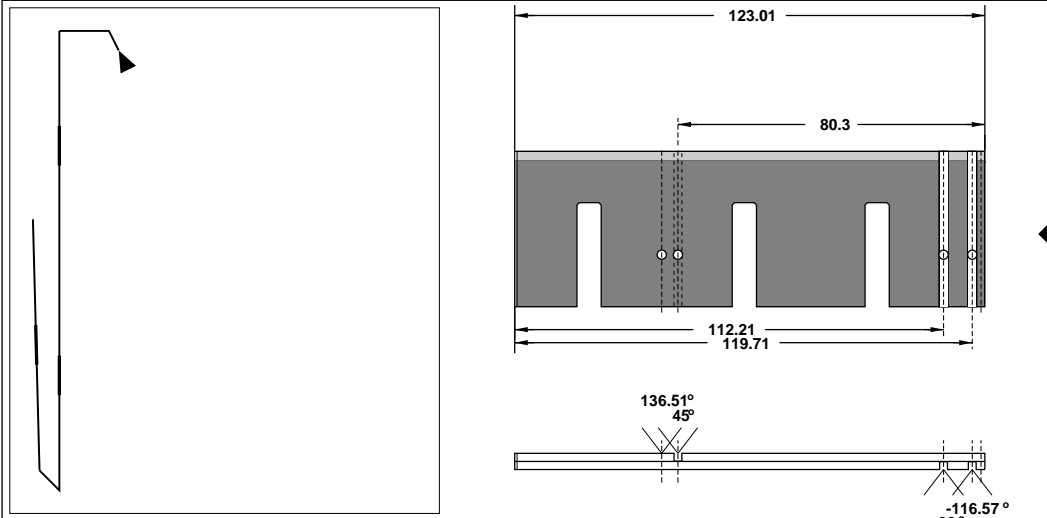

4	Line-No.	Date	27.02.2012	Order-No.		Amount	6	Supplier	
	Path	asercpack/filesW	Author	Yashin A	Height	23.80		Laserpack Fryazino	
	File	f> ECMA_F01...dds	Customer		Manufacturer	Boehler			
	10/15/18		Line type	PERFO	Material	UNIVERSAL-T30			
	Sonstiges		Pointage	2.00	Mat. Table	04	Die-Side		

Rule Processing System ACS 100 for ISO 9000

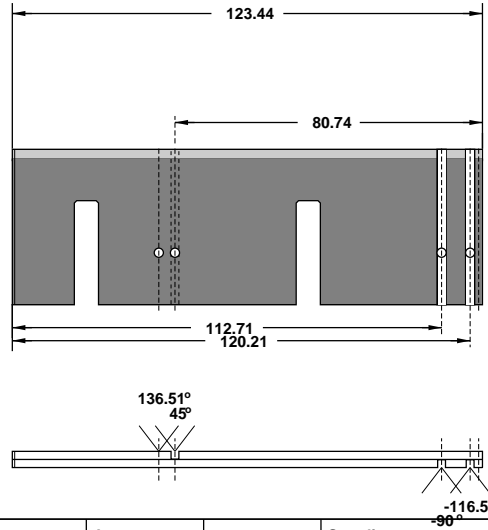
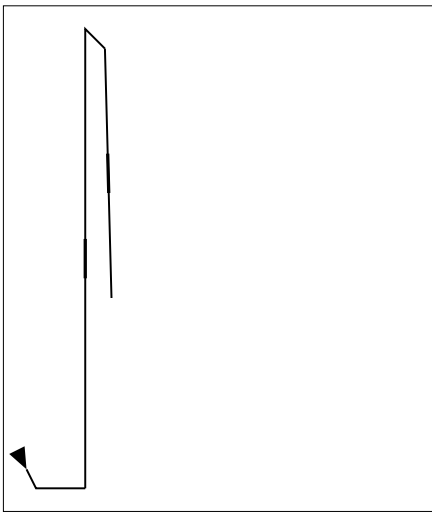

Line-No.	Date	27.02.2012	Order-No.		Amount	6	Supplier
5	Path	aserpack/filesW	Author	Yashin A	Height	23.80	Laserpack Fryazino
	File	f> ECMA_F01...dds	Customer		Manufacturer	Boehler	
	10/15/18		Line type	PERFO	Material	UNIVERSAL-T30	
	Sonstiges		Pointage	2.00	Mat. Table	04	
			Die-Side				

Rule Processing System ACS 100 for ISO 9000

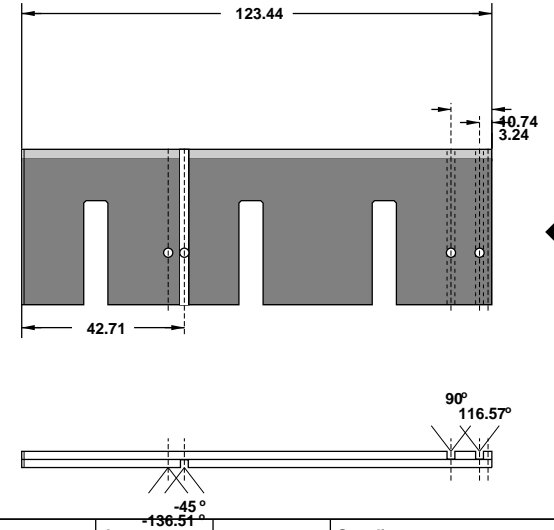
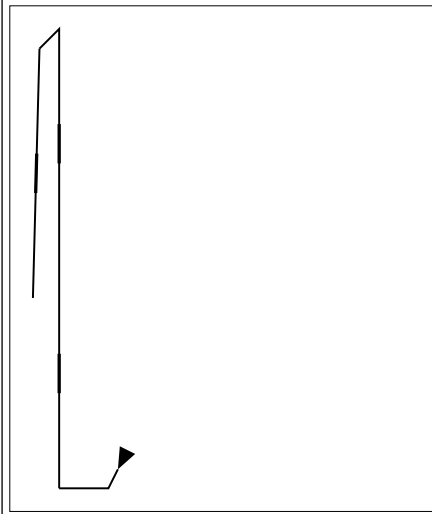

Line-No.	Date	27.02.2012	Order-No.		Amount	6	Supplier
6	Path	aserpack/filesW	Author	Yashin A	Height	23.80	Laserpack Fryazino
	File	f> ECMA_F01...dds	Customer		Manufacturer	Boehler	
	10/15/18		Line type	PERFO	Material	UNIVERSAL-T30	
	Sonstiges		Pointage	2.00	Mat. Table	04	
			Die-Side				

Rule Processing System ACS 100 for ISO 9000

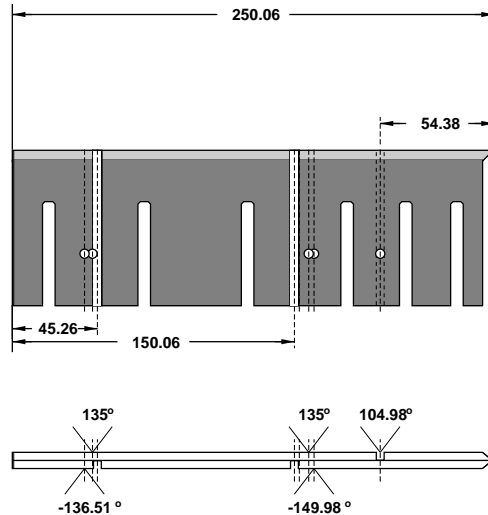
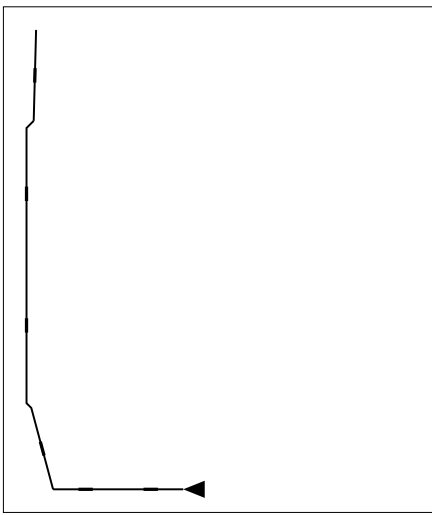

Line-No.	Date	27.02.2012	Order-No.		Amount	6	Supplier
7	Path	aserpack/filesW	Author	Yashin A	Height	23.80	Laserpack Fryazino
	File	f> ECMA_F01...dds	Customer		Manufacturer	Boehler	
	10/15/18		Line type	Cut	Material	UNIVERSAL-T30	
	Sonstiges		Pointage	2.00	Mat. Table	04	
			Die-Side				

Rule Processing System ACS 100 for ISO 9000

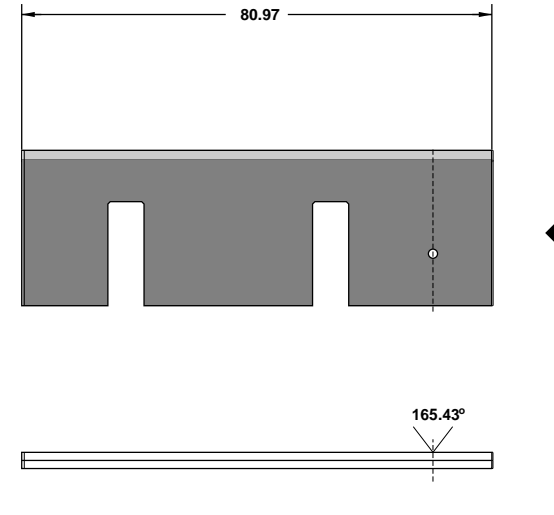
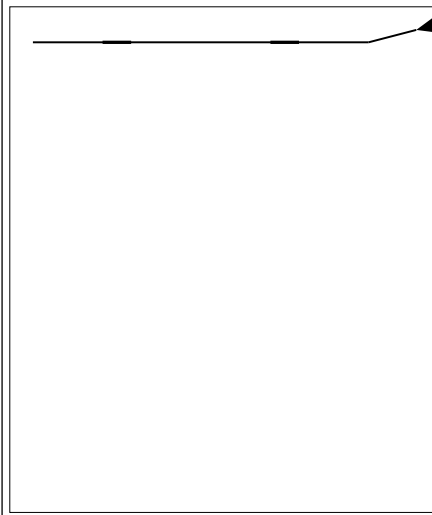

Line-No.	Date	27.02.2012	Order-No.		Amount	6	Supplier
8	Path	aserpack/filesW	Author	Yashin A	Height	23.80	Laserpack Fryazino
	File	f> ECMA_F01...dds	Customer		Manufacturer	Boehler	
	10/15/18		Line type	Cut	Material	UNIVERSAL-T30	
	Sonstiges		Pointage	2.00	Mat. Table	04	
			Die-Side				

Rule Processing System ACS 100 for ISO 9000

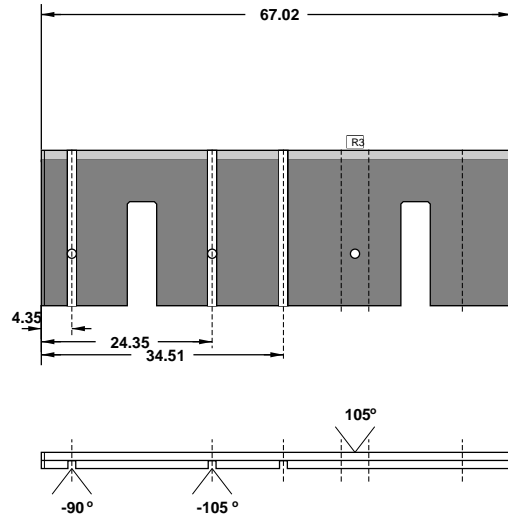
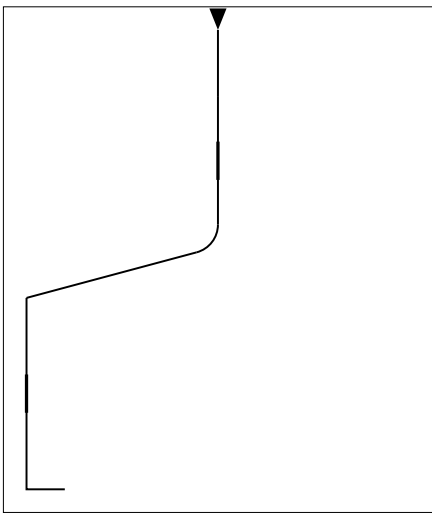

9	Line-No.	Date	27.02.2012	Order-No.		Amount	6	Supplier
	Path	asercpack/filesW	Author	Yashin A	Height	23.80	Laserpack Fryazino	
	File	f> ECMA_F01...dds	Customer		Manufacturer	Boehler		
	10/15/18		Line type	Cut	Material	UNIVERSAL-T30		
	Sonstiges		Pointage	2.00	Mat. Table	04		Die-Side

Rule Processing System ACS 100 for ISO 9000

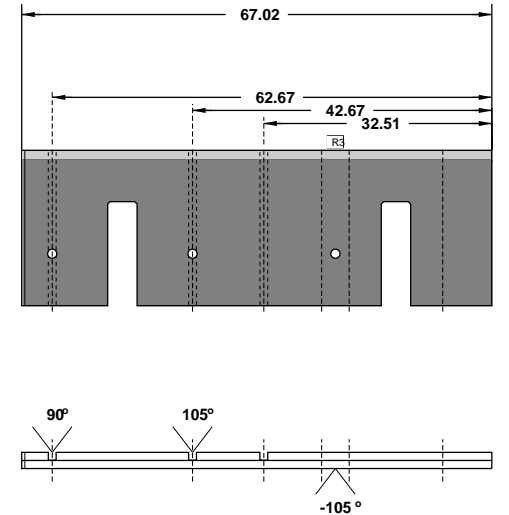
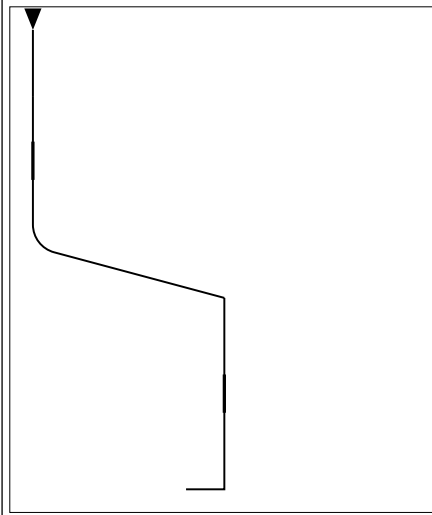

10	Line-No.	Date	27.02.2012	Order-No.		Amount	6	Supplier
	Path	asercpack/filesW	Author	Yashin A	Height	23.80	Laserpack Fryazino	
	File	f> ECMA_F01...dds	Customer		Manufacturer	Boehler		
	10/15/18		Line type	Cut	Material	UNIVERSAL-T30		
	Sonstiges		Pointage	2.00	Mat. Table	04		Die-Side

Rule Processing System ACS 100 for ISO 9000

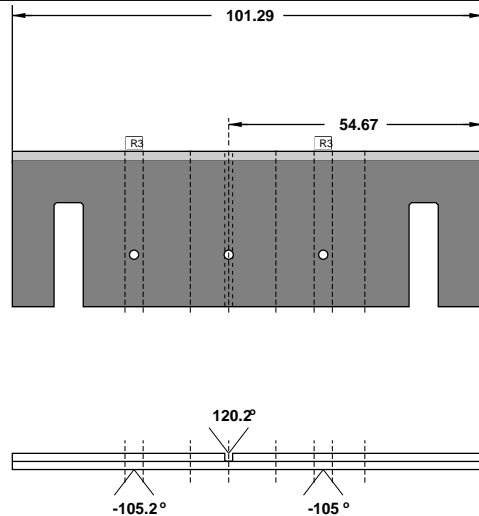
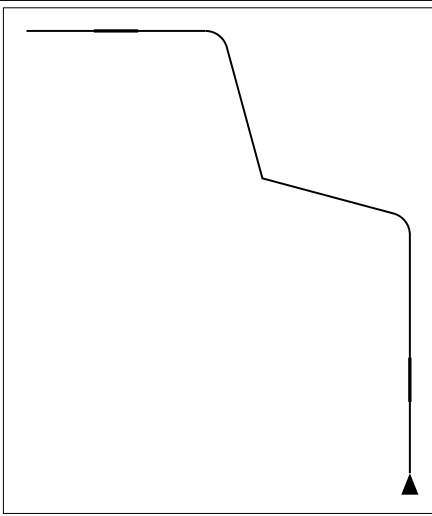

11	Line-No.	Date	27.02.2012	Order-No.		Amount	6	Supplier
	Path	asercpack/filesW	Author	Yashin A	Height	23.80	Laserpack Fryazino	
	File	f> ECMA_F01...dds	Customer		Manufacturer	Boehler		
	10/15/18		Line type	Cut	Material	UNIVERSAL-T30		
	Sonstiges		Pointage	2.00	Mat. Table	04		Die-Side

Rule Processing System ACS 100 for ISO 9000

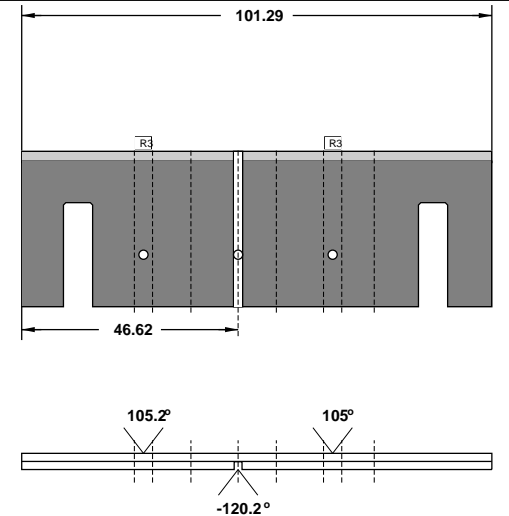
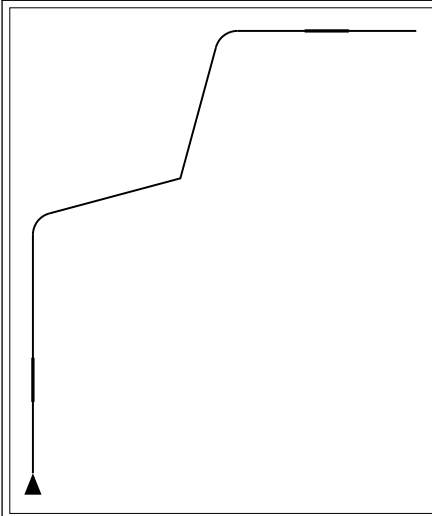

12	Line-No.	Date	27.02.2012	Order-No.		Amount	6	Supplier
	Path	asercpack/filesW	Author	Yashin A	Height	23.80	Laserpack Fryazino	
	File	f> ECMA_F01...dds	Customer		Manufacturer	Boehler		
	10/15/18		Line type	Cut	Material	UNIVERSAL-T30		
	Sonstiges		Pointage	2.00	Mat. Table	04		Die-Side

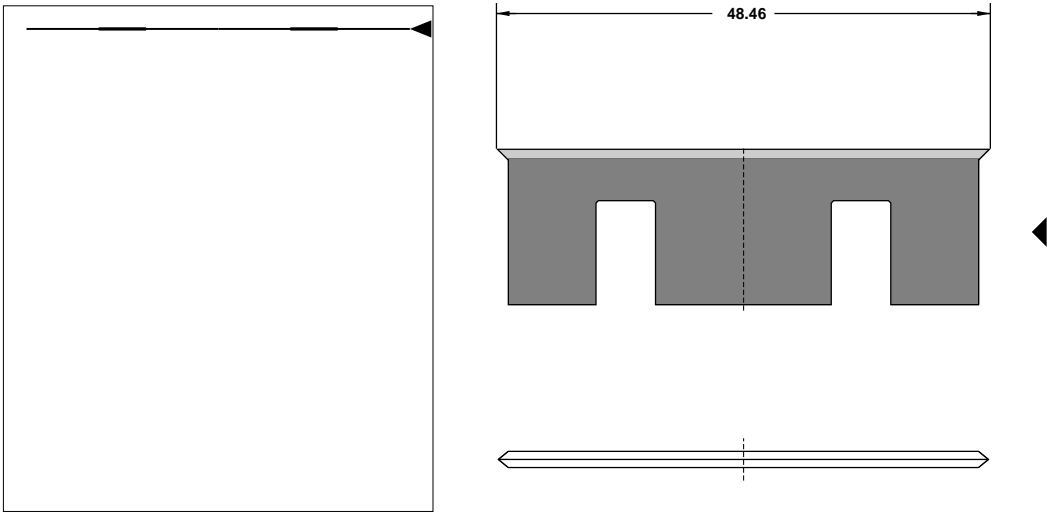

13	Line-No.	Date	27.02.2012	Order-No.		Amount	6	Supplier	
	Path	asercpack/filesW	Author	Yashin A	Height	23.80	Laserpack Fryazino		
	File	f> ECMA_F01...dds	Customer		Manufacturer	Boehler			
	10/15/18		Line type	Cut	Material	UNIVERSAL-T30			
	Sonstiges		Pointage	2.00	Mat. Table	04	Die-Side		

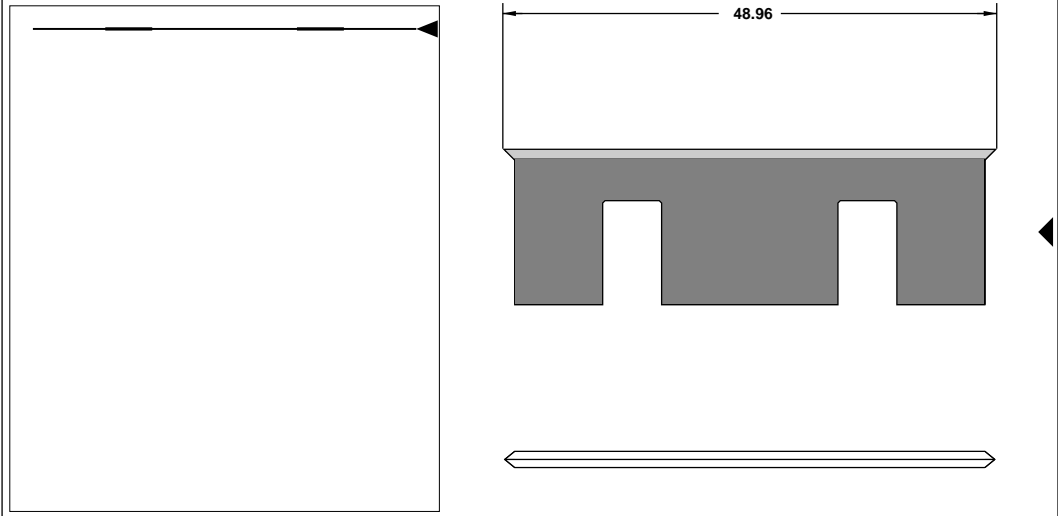

14	Line-No.	Date	27.02.2012	Order-No.		Amount	6	Supplier	
	Path	asercpack/filesW	Author	Yashin A	Height	23.80	Laserpack Fryazino		
	File	f> ECMA_F01...dds	Customer		Manufacturer	Boehler			
	10/15/18		Line type	Cut	Material	UNIVERSAL-T30			
	Sonstiges		Pointage	2.00	Mat. Table	04	Die-Side		

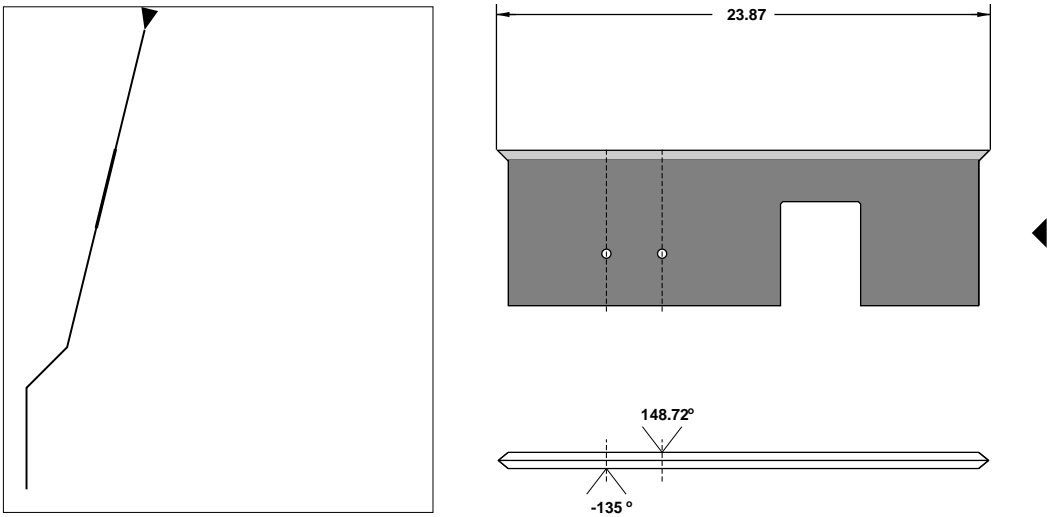

15	Line-No.	Date	27.02.2012	Order-No.		Amount	6	Supplier	
	Path	asercpack/filesW	Author	Yashin A	Height	23.80	Laserpack Fryazino		
	File	f> ECMA_F01...dds	Customer		Manufacturer	Boehler			
	10/15/18		Line type	Cut	Material	UNIVERSAL-T30			
	Sonstiges		Pointage	2.00	Mat. Table	04	Die-Side		

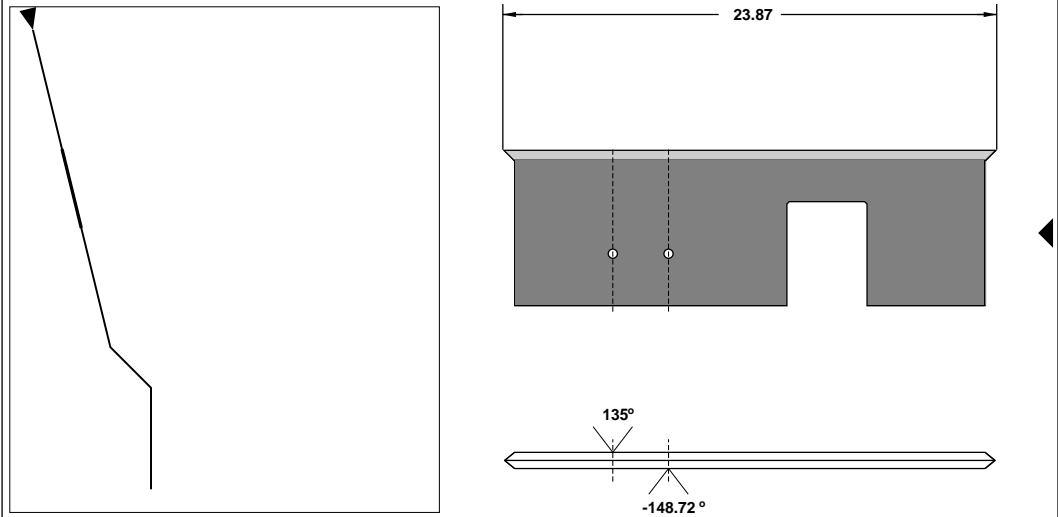

16	Line-No.	Date	27.02.2012	Order-No.		Amount	6	Supplier	
	Path	asercpack/filesW	Author	Yashin A	Height	23.80	Laserpack Fryazino		
	File	f> ECMA_F01...dds	Customer		Manufacturer	Boehler			
	10/15/18		Line type	Cut	Material	UNIVERSAL-T30			
	Sonstiges		Pointage	2.00	Mat. Table	04	Die-Side		

Rule Processing System ACS 100 for ISO 9000

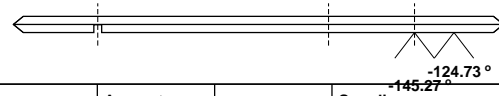
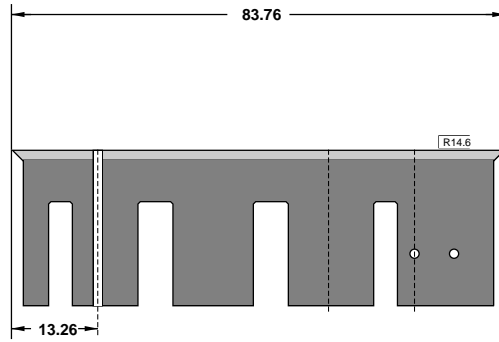
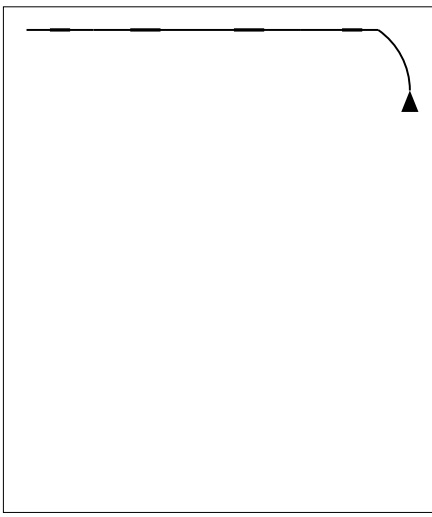

17	Line-No.	Date	27.02.2012	Order-No.		Amount	6	Supplier	
	Path	aserpack/filesW	Author	Yashin A	Height	23.80	Laserpack Fryazino		
	File	f> ECMA_F01...dds	Customer		Manufacturer	Boehler			
	10/15/18		Line type	Cut	Material	UNIVERSAL-T30			
	Sonstiges		Pointage	2.00	Mat. Table	04	Die-Side		

Rule Processing System ACS 100 for ISO 9000

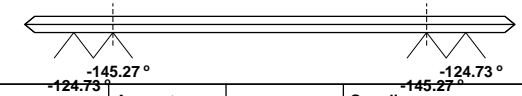
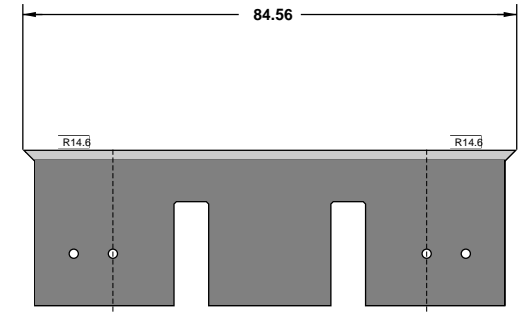
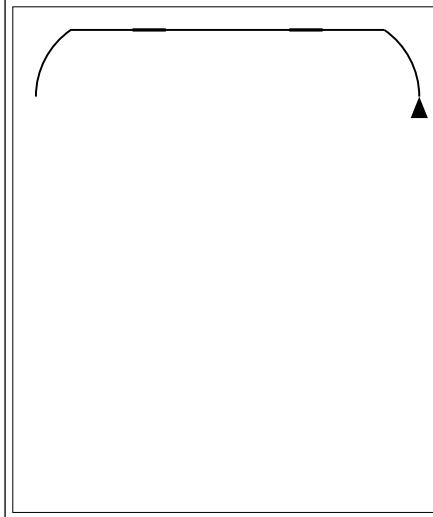

18	Line-No.	Date	27.02.2012	Order-No.		Amount	6	Supplier	
	Path	aserpack/filesW	Author	Yashin A	Height	23.80	Laserpack Fryazino		
	File	f> ECMA_F01...dds	Customer		Manufacturer	Boehler			
	10/15/18		Line type	Cut	Material	UNIVERSAL-T30			
	Sonstiges		Pointage	2.00	Mat. Table	04	Die-Side		

Rule Processing System ACS 100 for ISO 9000

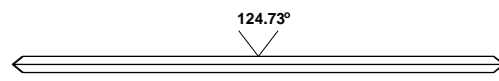
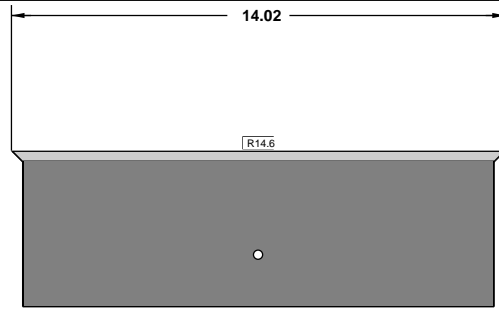
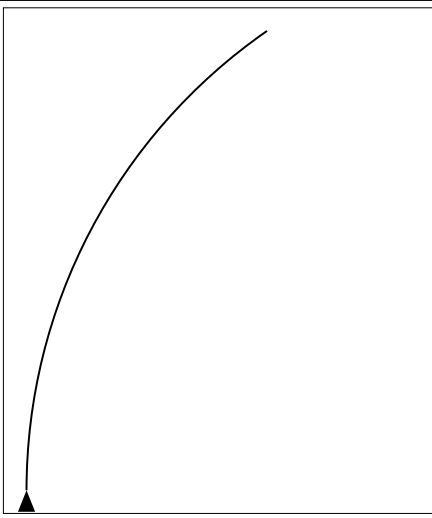

19	Line-No.	Date	27.02.2012	Order-No.		Amount	6	Supplier	
	Path	aserpack/filesW	Author	Yashin A	Height	23.80	Laserpack Fryazino		
	File	f> ECMA_F01...dds	Customer		Manufacturer	Boehler			
	10/15/18		Line type	Cut	Material	UNIVERSAL-T30			
	Sonstiges		Pointage	2.00	Mat. Table	04	Die-Side		

Rule Processing System ACS 100 for ISO 9000

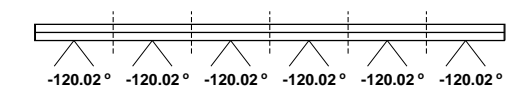
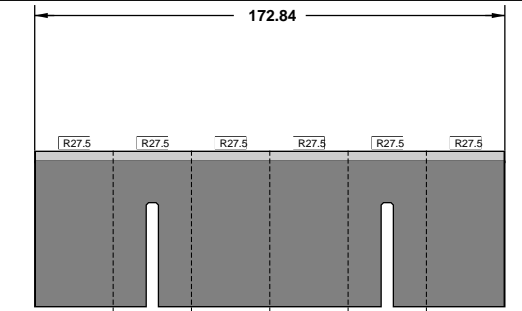
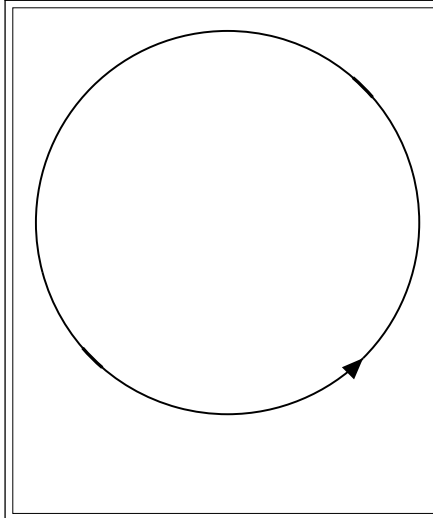

20	Line-No.	Date	27.02.2012	Order-No.		Amount	6	Supplier	
	Path	aserpack/filesW	Author	Yashin A	Height	23.80	Laserpack Fryazino		
	File	f> ECMA_F01...dds	Customer		Manufacturer	Boehler			
	10/15/18		Line type	Cut	Material	UNIVERSAL-T30			
	Sonstiges		Pointage	2.00	Mat. Table	04	Die-Side		

Rule Processing System ACS 100 for ISO 9000

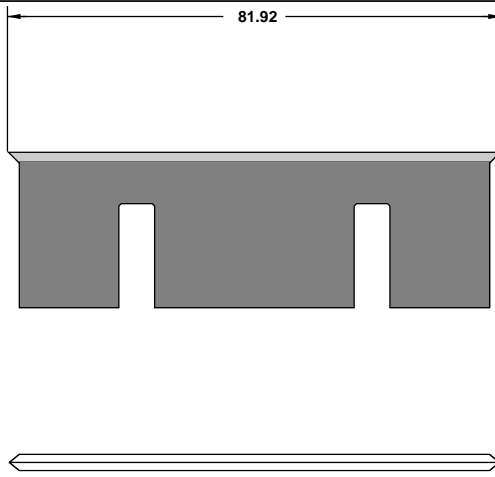
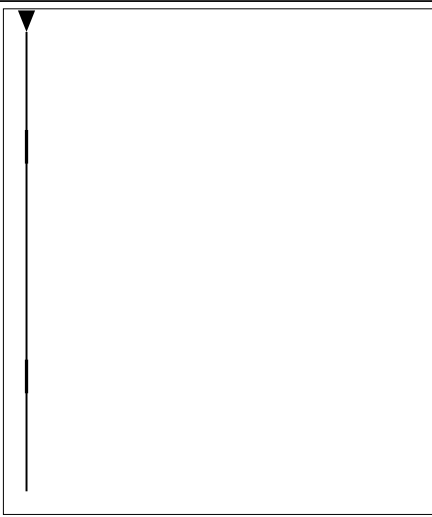

21	Line-No.	Date	27.02.2012	Order-No.		Amount	2	Supplier
	Path	aserpack/filesW	Author	Yashin A	Height	23.80	Laserpack Fryazino	
	File	f> ECMA_F01...dds	Customer		Manufacturer	Boehler		
	10/15/18		Line type	Cut	Material	UNIVERSAL-T30	Die-Side	
	Sonstiges		Pointage	2.00	Mat. Table	04		

Rule Processing System ACS 100 for ISO 9000

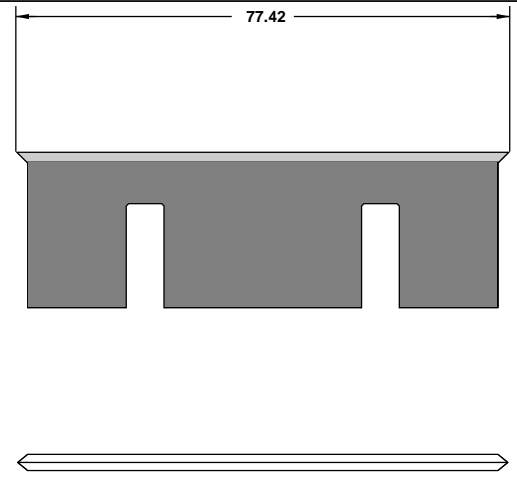

22	Line-No.	Date	27.02.2012	Order-No.		Amount	3	Supplier
	Path	aserpack/filesW	Author	Yashin A	Height	23.80	Laserpack Fryazino	
	File	f> ECMA_F01...dds	Customer		Manufacturer	Boehler		
	10/15/18		Line type	Cut	Material	UNIVERSAL-T30	Die-Side	
	Sonstiges		Pointage	2.00	Mat. Table	04		

Rule Processing System ACS 100 for ISO 9000

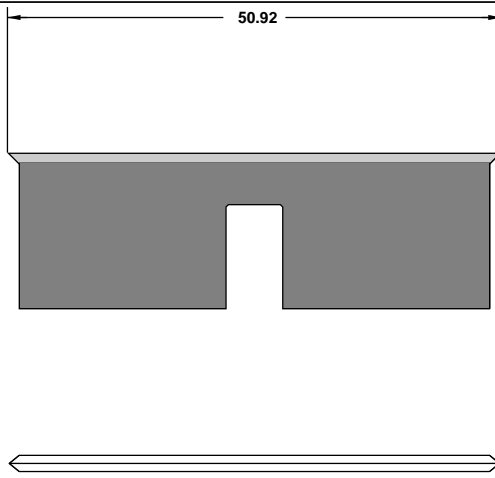
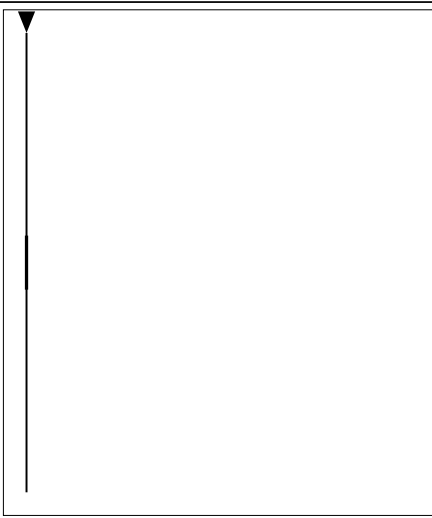

23	Line-No.	Date	27.02.2012	Order-No.		Amount	3	Supplier
	Path	aserpack/filesW	Author	Yashin A	Height	23.80	Laserpack Fryazino	
	File	f> ECMA_F01...dds	Customer		Manufacturer	Boehler		
	10/15/18		Line type	Cut	Material	UNIVERSAL-T30	Die-Side	
	Sonstiges		Pointage	2.00	Mat. Table	04		

Rule Processing System ACS 100 for ISO 9000

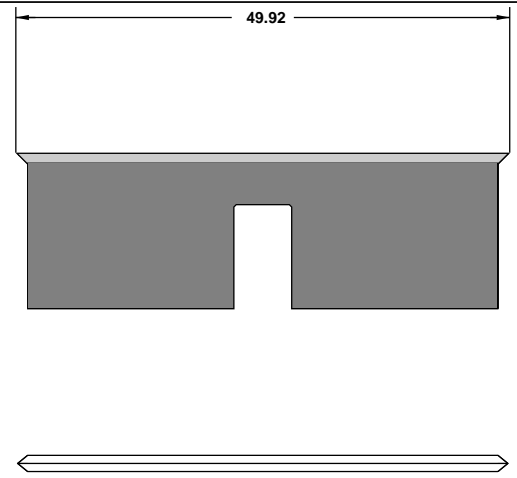
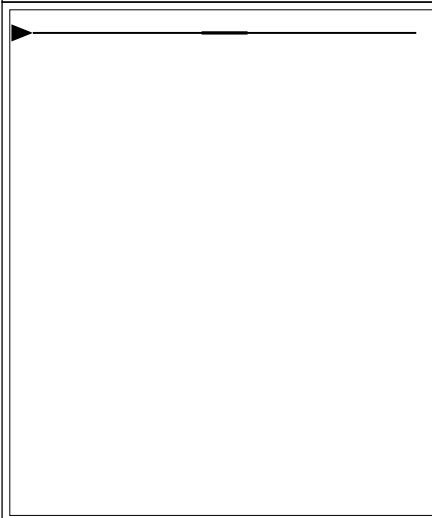

24	Line-No.	Date	27.02.2012	Order-No.		Amount	4	Supplier
	Path	aserpack/filesW	Author	Yashin A	Height	23.80	Laserpack Fryazino	
	File	f> ECMA_F01...dds	Customer		Manufacturer	Boehler		
	10/15/18		Line type	Cut	Material	UNIVERSAL-T30	Die-Side	
	Sonstiges		Pointage	2.00	Mat. Table	04		

Rule Processing System ACS 100 for ISO 9000

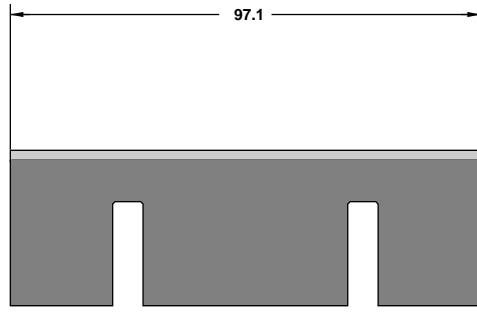
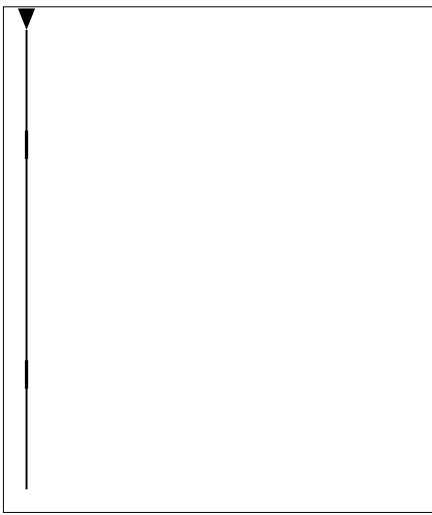

PERFO KLEEVAY

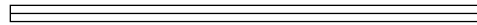

Line-No.	Date	27.02.2012	Order-No.		Amount	6	Supplier
25	Path	aserpack/filesW	Author	Yashin A	Height	23.80	Laserpack Fryazino
	File	f> ECMA_F01...dds	Customer		Manufacturer	Boehler	
	10/15/18		Line type	PERFO	Material	UNIVERSAL-T30	
	Sonstiges		Pointage	2.00	Mat. Table	04	
			Die-Side				

Rule Processing System ACS 100 for ISO 9000

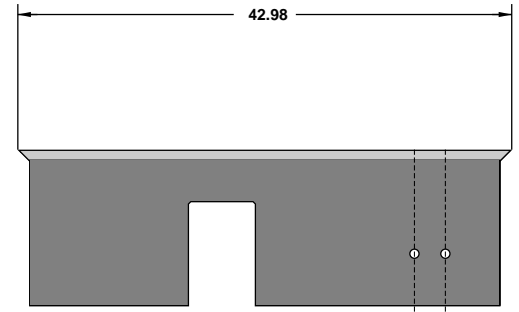
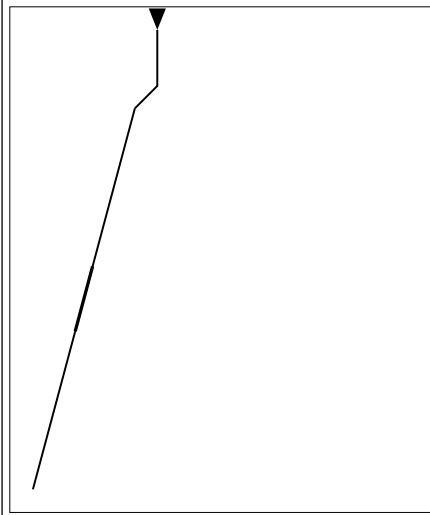

135°
-149.98°

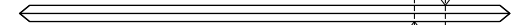

Line-No.	Date	27.02.2012	Order-No.		Amount	6	Supplier
26	Path	aserpack/filesW	Author	Yashin A	Height	23.80	Laserpack Fryazino
	File	f> ECMA_F01...dds	Customer		Manufacturer	Boehler	
	10/15/18		Line type	Cut	Material	UNIVERSAL-T30	
	Sonstiges		Pointage	2.00	Mat. Table	04	
			Die-Side				

Rule Processing System ACS 100 for ISO 9000

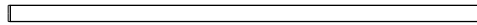
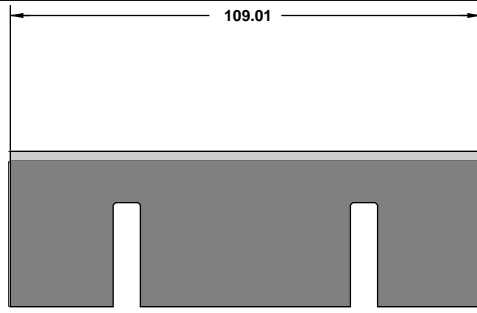
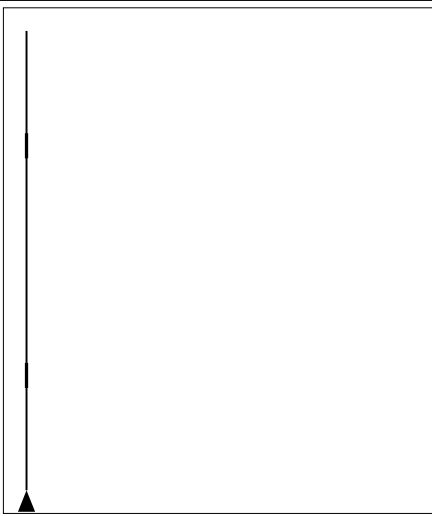

Line-No.	Date	27.02.2012	Order-No.		Amount	6	Supplier
27	Path	aserpack/filesW	Author	Yashin A	Height	23.20	Laserpack Fryazino
	File	f> ECMA_F01...dds	Customer		Manufacturer	Boehler	
	10/15/18		Line type	Crease	Material	UNIVERSAL-T30	
	Sonstiges		Pointage	2.00	Mat. Table	04	
			Die-Side				

Rule Processing System ACS 100 for ISO 9000

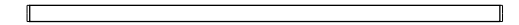
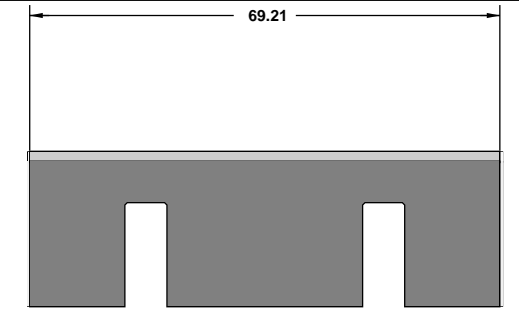
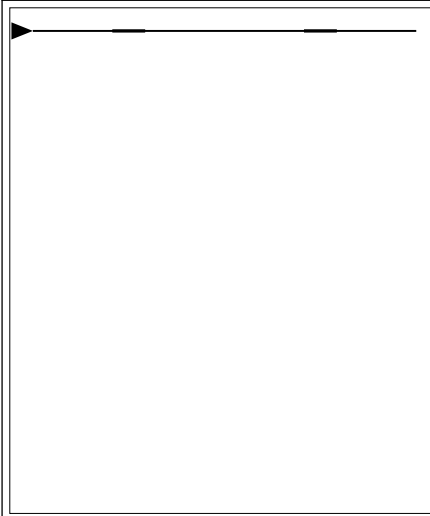

Line-No.	Date	27.02.2012	Order-No.		Amount	12	Supplier
28	Path	aserpack/filesW	Author	Yashin A	Height	23.20	Laserpack Fryazino
	File	f> ECMA_F01...dds	Customer		Manufacturer	Boehler	
	10/15/18		Line type	Crease	Material	UNIVERSAL-T30	
	Sonstiges		Pointage	2.00	Mat. Table	04	
			Die-Side				

Rule Processing System ACS 100 for ISO 9000

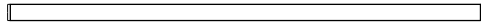
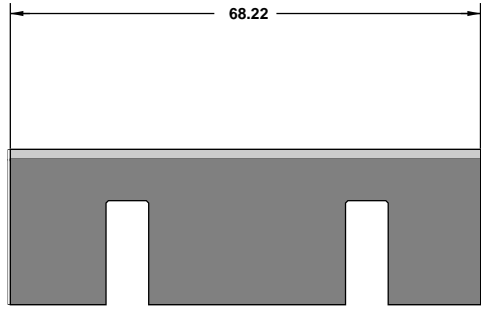
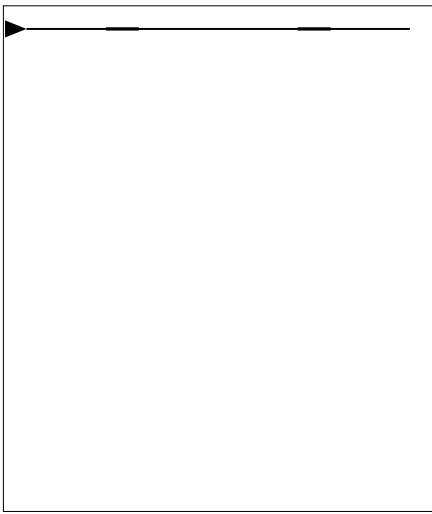

29	Line-No.	Date	27.02.2012	Order-No.		Amount	12	Supplier	
	Path	aserpack/filesW	Author	Yashin A	Height	23.20	Laserpack Fryazino		
	File	f> ECMA_F01...dds	Customer		Manufacturer	Boehler			
	10/15/18		Line type	Crease	Material	UNIVERSAL-T30			
	Sonstiges		Pointage	2.00	Mat. Table	04	Die-Side		

Rule Processing System ACS 100 for ISO 9000

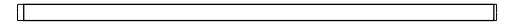
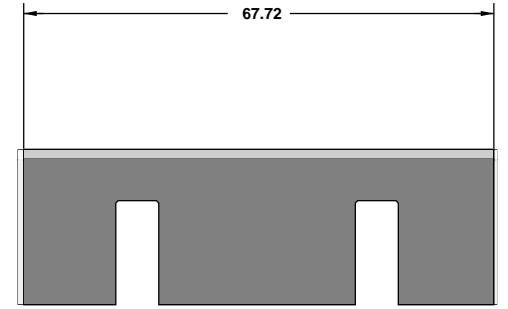
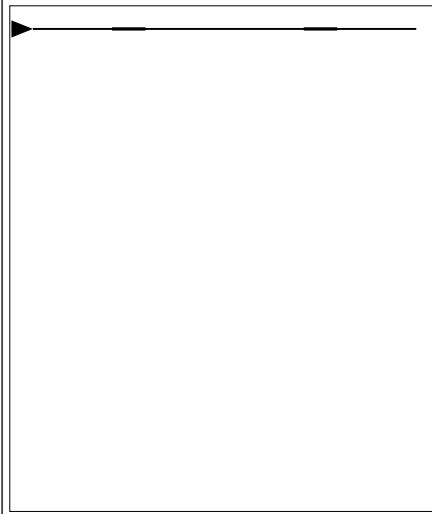

30	Line-No.	Date	27.02.2012	Order-No.		Amount	6	Supplier	
	Path	aserpack/filesW	Author	Yashin A	Height	23.20	Laserpack Fryazino		
	File	f> ECMA_F01...dds	Customer		Manufacturer	Boehler			
	10/15/18		Line type	Crease	Material	UNIVERSAL-T30			
	Sonstiges		Pointage	2.00	Mat. Table	04	Die-Side		

Rule Processing System ACS 100 for ISO 9000

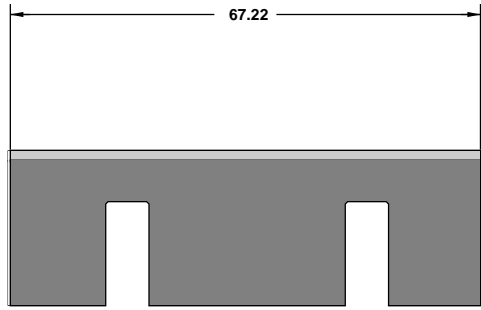
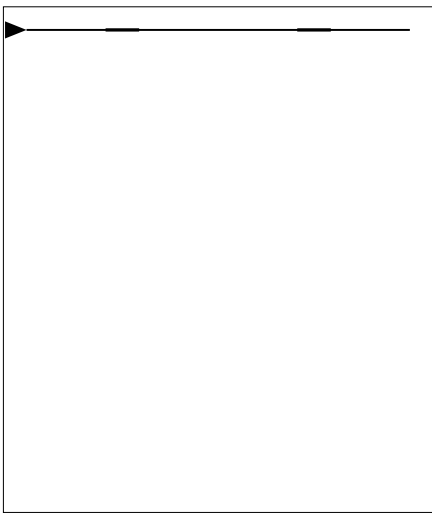

31	Line-No.	Date	27.02.2012	Order-No.		Amount	6	Supplier	
	Path	aserpack/filesW	Author	Yashin A	Height	23.20	Laserpack Fryazino		
	File	f> ECMA_F01...dds	Customer		Manufacturer	Boehler			
	10/15/18		Line type	Crease	Material	UNIVERSAL-T30			
	Sonstiges		Pointage	2.00	Mat. Table	04	Die-Side		

Rule Processing System ACS 100 for ISO 9000

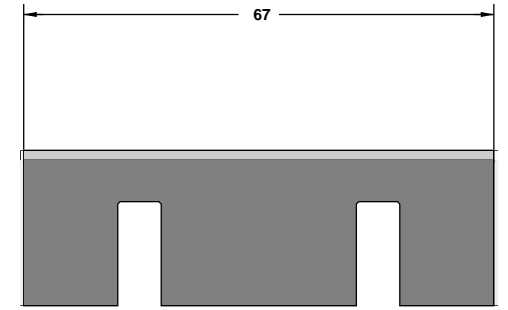

32	Line-No.	Date	27.02.2012	Order-No.		Amount	12	Supplier	
	Path	aserpack/filesW	Author	Yashin A	Height	23.20	Laserpack Fryazino		
	File	f> ECMA_F01...dds	Customer		Manufacturer	Boehler			
	10/15/18		Line type	Crease	Material	UNIVERSAL-T30			
	Sonstiges		Pointage	2.00	Mat. Table	04	Die-Side		

Rule Processing System ACS 100 for ISO 9000

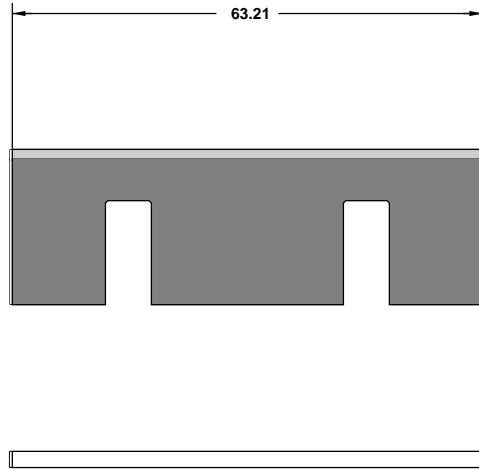
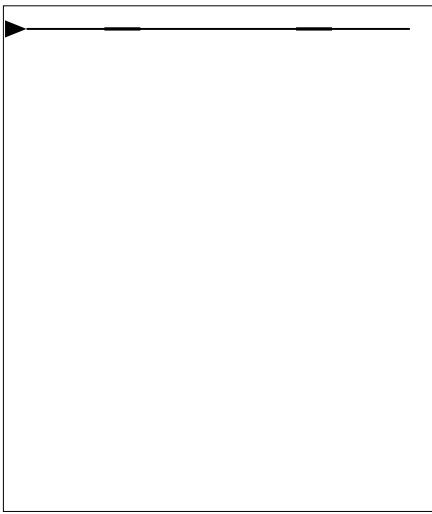

33	Line-No.	Date	27.02.2012	Order-No.		Amount	12	Supplier	
	Path	aserpack/filesW	Author	Yashin A	Height	23.20	Laserpack Fryazino		
	File	f> ECMA_F01...dds	Customer		Manufacturer	Boehler			
	10/15/18		Line type	Crease	Material	UNIVERSAL-T30			
	Sonstiges		Pointage	2.00	Mat. Table	04	Die-Side		

Rule Processing System ACS 100 for ISO 9000

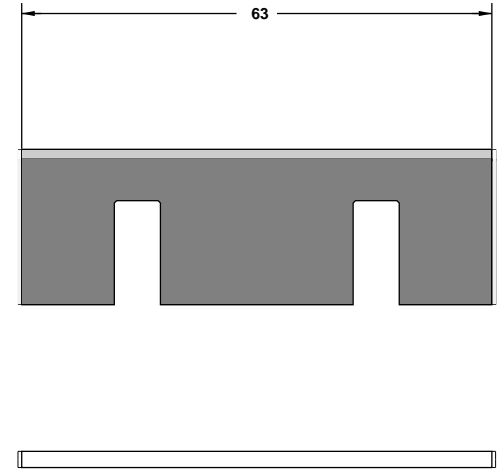
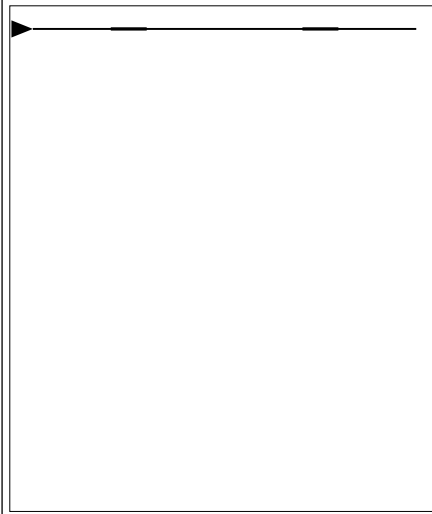

34	Line-No.	Date	27.02.2012	Order-No.		Amount	6	Supplier	
	Path	aserpack/filesW	Author	Yashin A	Height	23.20	Laserpack Fryazino		
	File	f> ECMA_F01...dds	Customer		Manufacturer	Boehler			
	10/15/18		Line type	Crease	Material	UNIVERSAL-T30			
	Sonstiges		Pointage	2.00	Mat. Table	04	Die-Side		

Rule Processing System ACS 100 for ISO 9000

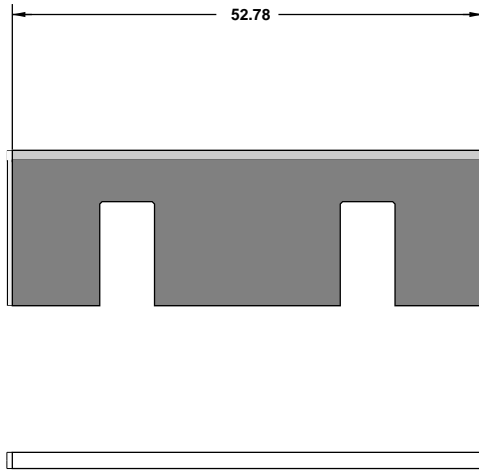
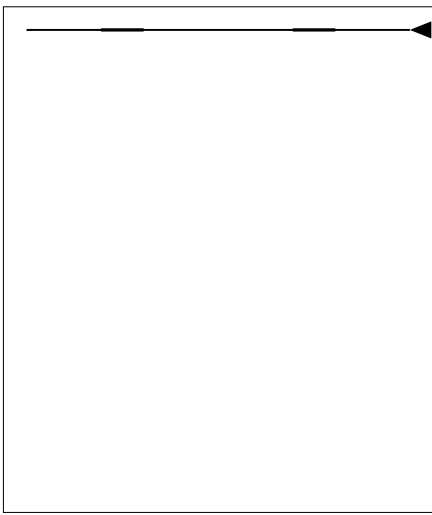

35	Line-No.	Date	27.02.2012	Order-No.		Amount	12	Supplier	
	Path	aserpack/filesW	Author	Yashin A	Height	23.20	Laserpack Fryazino		
	File	f> ECMA_F01...dds	Customer		Manufacturer	Boehler			
	10/15/18		Line type	Crease	Material	UNIVERSAL-T30			
	Sonstiges		Pointage	2.00	Mat. Table	04	Die-Side		

Rule Processing System ACS 100 for ISO 9000

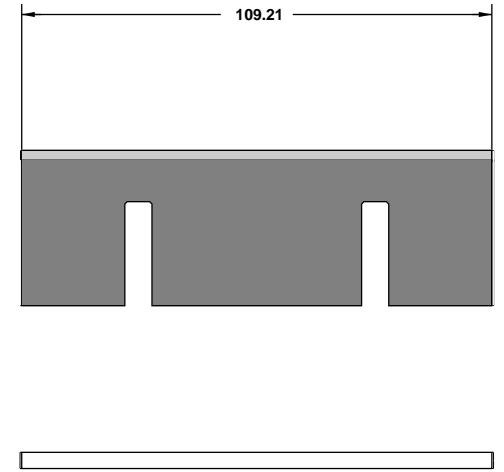

36	Line-No.	Date	27.02.2012	Order-No.		Amount	18	Supplier	
	Path	aserpack/filesW	Author	Yashin A	Height	23.20	Laserpack Fryazino		
	File	f> ECMA_F01...dds	Customer		Manufacturer	Boehler			
	10/15/18		Line type	Crease	Material	UNIVERSAL-T30			
	Sonstiges		Pointage	2.00	Mat. Table	04	Die-Side		

complete list

Date	File	Order-No.	Author	Customer	Up
27.02.2012	f> ECMA_F01...dds		Yashin A		1

No.	Line type	Height	Point.	Amount	Bridges		BEMDMARK		KBends		Broaching		Length	Sum	Total	Manufacturer	Mat. Table
					Sing.	Sum	Sing.	Sum	Sing.	Sum	Sing.	Sum					
1	Cut	23.80	2.00	3	12	36	0	0	0	0	0	0	868.50	2605.50		Boehler	04
2	Cut	23.80	2.00	2	2	4	0	0	0	0	2	4	114.80	229.60	2835.10	Boehler	04
3	PERFO	23.80	2.00	6	2	12	3	18	3	18	3	18	90.47	542.82		Boehler	04
4	PERFO	23.80	2.00	6	3	18	4	24	4	24	3	18	123.01	738.06		Boehler	04
5	PERFO	23.80	2.00	6	2	12	4	24	4	24	3	18	123.44	740.64		Boehler	04
6	PERFO	23.80	2.00	6	3	18	4	24	4	24	3	18	123.44	740.64	2762.16	Boehler	04
7	Cut	23.80	2.00	6	6	36	5	30	5	30	3	18	250.06	1500.36		Boehler	04
8	Cut	23.80	2.00	6	2	12	1	6	1	6	0	0	80.97	485.82		Boehler	04
9	Cut	23.80	2.00	6	2	12	3	18	2	12	3	18	67.02	402.12		Boehler	04
10	Cut	23.80	2.00	6	2	12	3	18	2	12	3	18	67.02	402.12		Boehler	04
11	Cut	23.80	2.00	6	2	12	3	18	1	6	1	6	101.29	607.74		Boehler	04
12	Cut	23.80	2.00	6	2	12	3	18	1	6	1	6	101.29	607.74		Boehler	04
13	Cut	23.80	2.00	6	2	12	0	0	0	0	0	0	48.46	290.76		Boehler	04
14	Cut	23.80	2.00	6	2	12	0	0	0	0	0	0	48.96	293.76		Boehler	04
15	Cut	23.80	2.00	6	1	6	2	12	2	12	0	0	23.87	143.22		Boehler	04
16	Cut	23.80	2.00	6	1	6	2	12	2	12	0	0	23.87	143.22		Boehler	04
17	Cut	23.80	2.00	6	4	24	2	12	1	6	1	6	83.76	502.56		Boehler	04
18	Cut	23.80	2.00	6	2	12	4	24	2	12	0	0	84.56	507.36		Boehler	04
19	Cut	23.80	2.00	6	0	0	1	6	0	0	0	0	14.02	84.12		Boehler	04
20	Cut	23.80	2.00	6	2	12	0	0	0	0	0	0	172.84	1037.04		Boehler	04

complete list

Date	File	Order-No.	Author	Customer	Up
27.02.2012	f> ECMA_F01...dds		Yashin A		1

No.	Line type	Height	Point.	Amount	Bridges		BEMDMARK		KBends		Broaching		Length	Sum	Total	Manufacturer	Mat. Table	
					Sing.	Sum	Sing.	Sum	Sing.	Sum	Sing.	Sum						
21	Cut	23.80	2.00	2	2	4	0	0	0	0	0	0	81.92	163.84		Boehler	04	
22	Cut	23.80	2.00	3	2	6	0	0	0	0	0	0	77.42	232.26		Boehler	04	
23	Cut	23.80	2.00	3	1	3	0	0	0	0	0	0	50.92	152.76		Boehler	04	
24	Cut	23.80	2.00	4	1	4	0	0	0	0	0	0	49.92	199.68	7756.48	Boehler	04	
25	PERFO	23.80	2.00	6	2	12	0	0	0	0	0	0	97.10	582.60	582.60	Boehler	04	
26	Cut	23.80	2.00	6	1	6	2	12	2	12	0	0	42.98	257.88	257.88	Boehler	04	
27	Crease	23.20	2.00	6	2	12	0	0	0	0	0	0	109.01	654.06		Boehler	04	
28	Crease	23.20	2.00	12	2	24	0	0	0	0	0	0	69.21	830.52		Boehler	04	
29	Crease	23.20	2.00	12	2	24	0	0	0	0	0	0	68.22	818.64		Boehler	04	
30	Crease	23.20	2.00	6	2	12	0	0	0	0	0	0	67.72	406.32		Boehler	04	
31	Crease	23.20	2.00	6	2	12	0	0	0	0	0	0	67.22	403.32		Boehler	04	
32	Crease	23.20	2.00	12	2	24	0	0	0	0	0	0	67.00	804.00		Boehler	04	
33	Crease	23.20	2.00	12	2	24	0	0	0	0	0	0	63.21	758.52		Boehler	04	
34	Crease	23.20	2.00	6	2	12	0	0	0	0	0	0	63.00	378.00		Boehler	04	
35	Crease	23.20	2.00	12	2	24	0	0	0	0	0	0	52.78	633.36		Boehler	04	
36	Crease	23.20	2.00	18	2	36	0	0	0	0	0	0	109.21	1965.78	7652.52	Boehler	04	
							239		519		276		216		148		21846.74	